

## MINI-REPORT 2005

### INDUSTRIAL OUTREACH PROGRAM IN MEXICO – QUERETARO



WEST VIRGINIA UNIVERSITY  
and the  
COUNCIL FOR SCIENCE AND TECHNOLOGY  
OF QUERETARO (CONCyTEQ)

Participating Institutions:

UNIVERSIDAD AUTONOMA DE QUERETARO (UAQ)  
INSTITUTO TECNOLÓGICO DE QUERETARO (ITQ)  
INSTITUTO TECNOLÓGICO DE ESTUDIOS  
SUPERIORES DE MONTERREY (ITESM)  
UNIV. NACIONAL AUTONOMA DE MÉXICO (UNAM)



WVU and Mexican students pose for a picture after a friendly game of fast soccer

This year, Dr. Victor Mucino took 12 WVU students to team up with 13 Mexican students in the **Industrial Outreach Program in Mexico**. This is an “Extended Learning” Program the Department of Mechanical and Aerospace Engineering (MAE) has developed in coordination with the Council for Science and Technology of the State of Queretaro (CONCyTEQ) in Mexico. During six weeks in the summer, WVU senior engineering students team up with Mexican

engineering students from various universities in Queretaro and form intermixed working groups. Each group is assigned to work at an industrial site on engineering problems, which are the tackled working alongside with engineers from industry. The environment is a professional one but with the added dimension of a cultural and a language immersion, which brings about cultures and personalities from the two countries, five institutions and as many industries involved.



WVU and Mexican students congratulate each other after finishing their final presentations

### Objectives of the Program

The objective of this program is first and foremost, to add value to engineering education and to produce top quality engineering graduates, by providing a meaningful industrial exposure in a multicultural and multilingual professional environment. The program also seeks to bring value to industry through the projects assigned to the participating students, who develop practical engineering skills as well as communication, leadership and human-relations skills.

Finally, this program seeks to bring faculty and engineers from industry to share expertise in formulating and solving engineering problems.

By teaming up with Mexican students, WVU students acquire a cultural exposure that is reciprocated to the Mexican students. The mix of professional environment with a different culture provides a framework that brings

an added dimension to the whole experience. Students learn and fine-tune their engineering skills while they hone their communication and interpersonal skills. At the end of the six-week exercise, students give a professional presentation to the sponsored industries using the Spanish that they learn while working with Mexican professionals, while Mexican students deliver their presentation in English they learn with the help of our students. This is a character- building exercise that brings the cultures and personalities to the forefront of the projects. Students live with local families who provide a home away from home environment for a total cultural immersion.

### Description of Sample Projects

This year 9 different projects were conducted with 6 different companies, such as CIAT (General-Electric Air-Craft Engines), Arvin-Meritor, Condumex-Gabriel, MABE (General-Electric Appliances), Tremec and CENAM (Mexico's NIST). The projects ranged from design assessment and trouble shutting to industrial design process analysis and development, including fieldwork, engineering design and system modeling and analysis.

### Project at MABE (GE-Appliances)

Two different projects were undertaken at MABE. The first involved the design, analysis and testing of components for domestic appliances. Finite element modeling of these systems was made to design specific components. The student team developed alternate designs, which were also modeled, analyzed and scrutinized by Mabe's engineers.

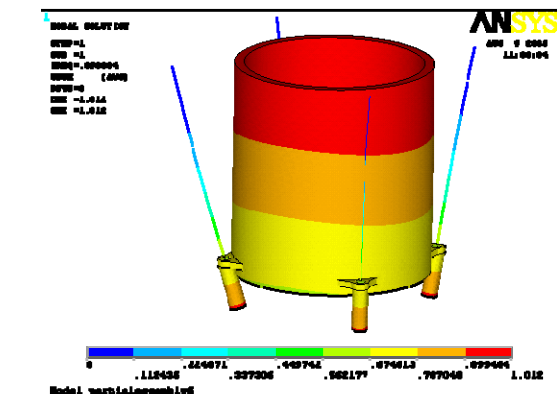

Finite element model of washing machine suspension.

The second project was designing a test rig that was capable of obtaining the Q value of various heat

exchangers. The test rig was designed to accommodate any size and type of HX used at Mabe for application in refrigerators.

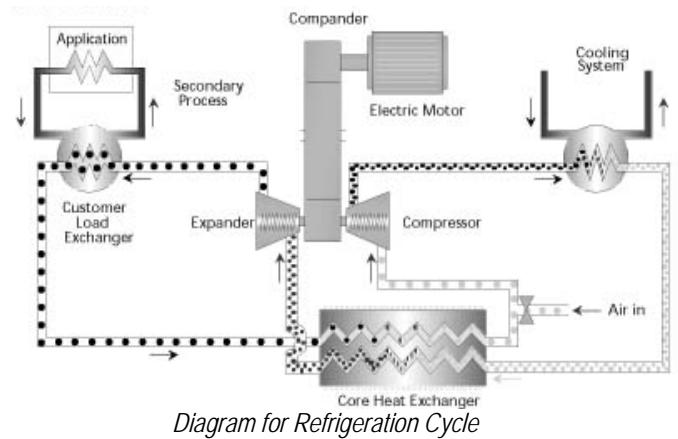

### Project at CONDUMEX-Gabriel

The student team was assigned to proposed improvements in the design of an automotive strut. Various perspectives were considered including strength characteristics and manufacturing considerations.

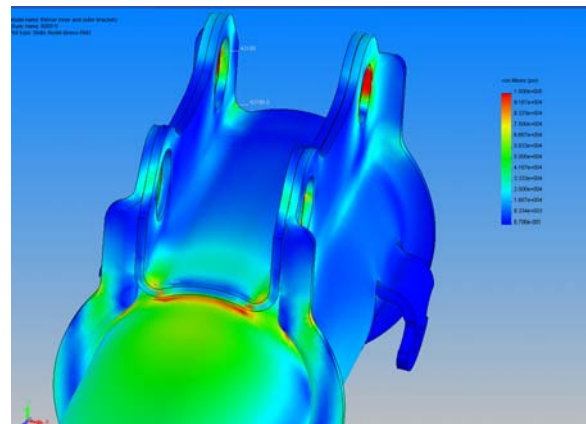

Finite element model of key stresses on a commercial strut

Finite element models were developed for the current design and alternate proposed designs to establishing a comparison frame from which the best design can be selected.

### Project at CENAM (Mexico's NIST)

The project at CENAM involved the experimental study on friction stir welding. The objectives of this group was to determine the parameters of the FSW process, perform tests with friction-stir-spot-welding, and friction-stir-linear-welding, and obtain as many results from the welding process as possible.

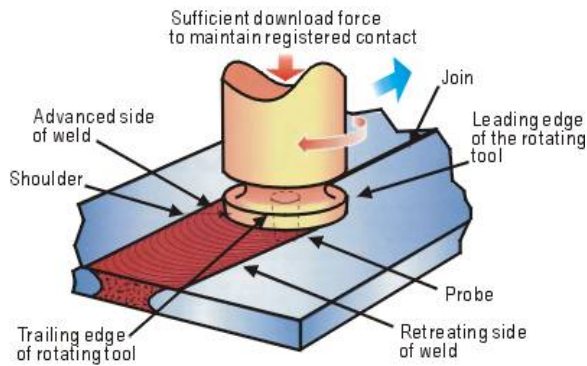

AZOM.COM™

Friction Stir welding diagram.

### Project at Arvin-Meritor

Arvin Meritor is a worldwide supplier of integrated systems, modules, and components for light vehicles, commercial trucks, trailers, and specialty OEMs and related aftermarkets. The operation based in Queretaro, Mexico specializes in producing struts, suspension systems, and exhausts. The plant operates in an assembly line and time and production are highly valued. This group analyzed an existing machine and designed new parts in order to reduce scrap and increase production. Also, a cost analysis of the stations was done in order to provide the company with a clearer outlook of the process.

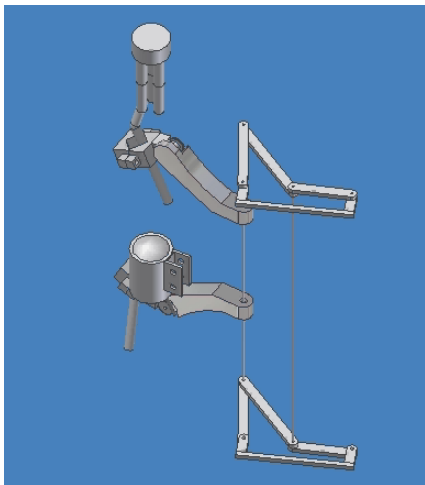

Model of the new machine designed for welding struts

### Project at CIAT (GE-Aircraft Engines)

Two projects were performed at CIAT; the first involved the heat transfer phenomenon that occurs with the aircraft engine systems. The second consisted of analyzing the mechanical response of some aircraft engine components. Students developed predictive models based on experimental data as well as finite element models to assess engine/part performance.



Model of an aircraft engine

### Tremec

The main objective of this project was to help TREMEC model a new design of two different CVT's (continuously variable transmission). Specifically, the objective was to describe the power recirculation flow and the power-split features of the system. A prototype was used for the modeling and analyses performed.

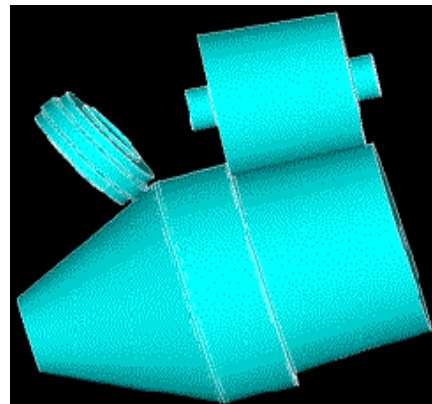

Basic Solid model of IVT rollers

### 9 Year Summary

In nine years, this program has impacted more than 120 students in Mexico and WVU, through over 40 industrial projects, worked with 6 institutions in Mexico, and about 20 different industries. The summary table below provides a quick reference on the impact of this program.

### Cultural Highlights

Cultural opportunities are plentiful throughout the six weeks. From archeological sightseeing to horse back riding outings to golden sunset in Acapulco in the company of Mexican students.

Host families also provide a major cultural opportunity, as they provide a "home away from home" environment, clean and safe environment along with some kind of an "extended family" feeling. Students learn about Mexican food, Spanish, traditions and participate fully on social activities with the friendly local people of Queretaro.

### Conclusion

Our Program is unique. It pursues the main objective of adding value to engineering education through an industrial exercise in an international setting. The program addresses issues that range from communication skills and cultural differences to human relations in the context of a practical engineering project. This experience has brought forward not only the practical engineering dimension, but also the human dimension that comes with the territory.

Indeed, cultural differences actually exist. They come forward when people disagree, when people negotiate and when people reach agreements. Those differences are inherent in the concept of "value" as well as in attitudes toward life. But being able to understand and better yet, anticipate cultural differences may be the difference between failure and success in professional situations in today's industry. In an increasingly globalized professional environment, we are doing our share to meet the challenge.



*Scuba diving in Acapulco*



*WVU Students with Dr. Mucino, enjoying the archeological site of Teotihuacan*



*American students take a break during a hike at Pena de Bernal*

*Industrial Outreach Program in Mexico: A Professional and Cultural Immersion*



*WVU students enjoy horseback riding on the beach*



*Hanging out on top of the Teotihuacan Pyramid*

<b>Institutions Involved</b>	<b>Participant students</b>	<b>Faculty from both countries</b>	<b>Industrial Liaisons</b>	<b>Industries/Research Centers</b>	<b>Projects developed</b>
<ul style="list-style-type: none"> <li>• West Virginia University</li> <li>• University of Guanajuato</li> <li>• University of Queretaro</li> <li>• Institute of Technology of Queretaro</li> <li>• CONCyTEQ Queretaro</li> <li>• ITESM (Tec. De Monterrey)</li> <li>• UNAM</li> </ul>	83 (WVU) 10 (UG) 36 (UAQ) 31 (ITQ)	3 (WVU) 2 (UG) 4 (UAQ) 4 (ITQ) 2 (ITESM)	(2) GM (Gto) (4) TREMEC (Qro) (2) Transm-TSP (Qro) (1) Micro-Troq. (Qro) (3) IMT (Qro) (2) LAPEM (Gto) (2) I. Turbo Reactores (1) Terramite (WV) (3) KOSA (3) New Holland (1) InMec (1) CENAM (2) ANSYS Mexico (1) Irving de Mexico (1) Crown Mexico (2) Arvin-Meritor (2) Gabriel (3) Mabe-GE Appliances (2) ConduMex (4) CIAT-GE Aircraft E.	GM TREMEC Transm-TSP Micro-Troquelados IMT* LAPEM* I. TurboReactores Terramite Corp.** KOSA New Holland InMec CENAM Grupo SSC (ANSYS) Irving- Composites Crown Mexico Mabe ConduMex Arvin Meritor CIAT-GE Aircraft E. Gabriel  * Research Centers ** From West Virginia	(1) GM Mexico (8) TREMEC (4) SPICER-TSP (1) Micro-Troq. (4) IMT (2) LAPEM (2) I. TurboReactores (1) TerramiteCorp.** (3) KOSA (3) New Holland (1) InMec (3) CENAM (1) Irving (1) Crown (4) CIAT (2) ConduMex (4) Mabe (2) Arvin Meritor (2) Gabriel  ** From West Virginia
<b>7 Institutions</b>	<b>150 Students</b>	<b>15 Faculty</b>	<b>42 Liaisons</b>	<b>20 Companies</b>	<b>49 Projects</b>

***Nine-year summary table of people, companies and projects developed in this Program.***

**Direct inquiries to:**

Dr. Victor H. Mucino , Professor Mechanical and Aerospace Engineering West Virginia University P.O. Box 6106 Morgantown, WV 26506-6106 Tel. (304)293-3111 ext. 2315 Fax (304) 293 6689 Email: <a href="mailto:vhmucino@mail.wvu.edu">vhmucino@mail.wvu.edu</a>	Dr. Alejandro Lozano Director CONCYTEQ Luis Pasteur Sur No. 36, Centro 76000 Queretaro, Oro. Mexico Tel. (52-442) 212-7266 Fax (52-442) 212-6156 Email: <a href="mailto:alcctq@concyteq.mx">alcctq@concyteq.mx</a>
---	---